

How to control DC motors with an H-Bridge IC

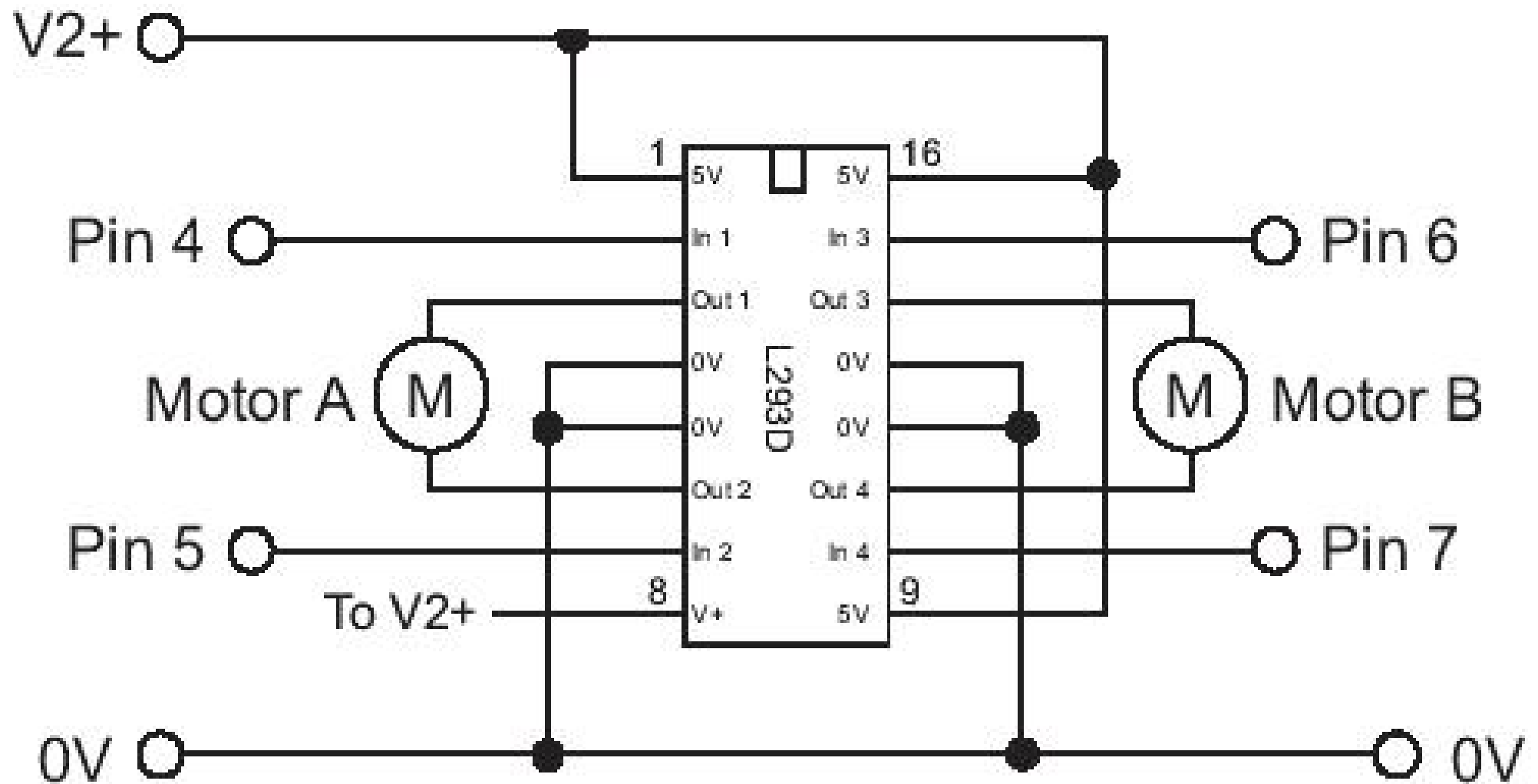

Both inputs low - motor halt

First output high, second output low - motor forward

First output low, second output high - motor reverse

Both inputs high - motor halt